

3F3A-132MA-4B5

MECHANICAL DATA

Noise at 50Hz	71 dB(A)
Moment of inertia	0.04865 kgm ²
Bearing DE	6208ZZ
Bearing NDE	6208ZZ
Bearing lifetime	40000 h
Direction of rotation	bidirectional
Frame material	aluminum
Colour	RAL 7030
Cooling method	IC411
Ambient temperature	-20 / +40 °C
Altitude above sealevel	1000 m
Output	7.5kW
Speed	1460 rpm
Ins. Class	F
Efficiency	90,4% IE3
Voltage	400V
Connection	D
F.L. Current	14.3A
Power factor	0,84
Duty	S1
Frequency	50 Hz
IP	55
Weight	63 kg

ELECTRICAL TEST DATA

Ambient temperature	26 °C
Resistance of winding	0,741 Ω
Three phase current unbalanced	1,5 %
No load amps	6,117 A
No load input	440,2 W
Core loss (Pfe)	208,89 W
Windage friction loss (Pfw)	52,45 W
Stator winding loss (Pcu1)	282,7 W
Rotor winding loss (Pcu2)	197,6 W
Stray load loss (Ps)	130,4 W
Locked rotor current	113,828 A
Locked rotor current / Full load current	7,96
Full load torque	49,1 Nm
Locked rotor input power at full load	36455,5 W
Locked rotor torque	117,1 Nm
Locked rotor torque / Full load torque	2,38
Full load input	8372 W
Full load current	14,19 A
Efficiency at 50% load	89,52 %
Efficiency at 75% load	90,3 %
Efficiency at 100% load	89,58 %
Power factor at full load	0,8518
Full load slip	2,507 %
Full load speed	1462,40 rpm
Stator winding temperature rise	53,1 K
Stator phase resistance at Ambient temperature of 95 °C	0,936 Ω
Sound pressure level	65 dB(A)
Vibration	0,8 mm/s
Insulation resistance	200 MΩ
Bearing temperature	56,6 °C

SPECIAL DESIGN

Efficiency in compliance with IEC 60034-30 Edition 1.0 - 2008, IE3
Testing method IEC 60034-2-1 Edition 1.0 - 2007-09

DIMENSIONS 3F3A-132MA-4B5

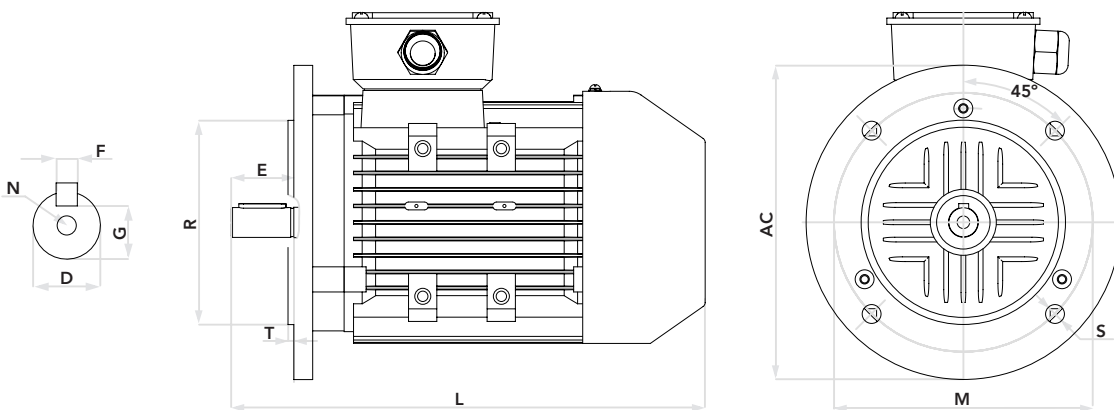

Frame size	Number of poles	D	E	F	G	M	N	R	S	T	AC	L
132MA	04	38	80	10	33	265	M12	230	4-14.5	4	275	510

FELSTROM

3F3A-132MA-4B5

