

# 3F3A-90LA-4B14

## MECHANICAL DATA

Noise at 50Hz	59 dB(A)
Moment of inertia	0.00312 kgm <sup>2</sup>
Bearing DE	6205ZZ
Bearing NDE	6203ZZ
Bearing lifetime	40000 h
Direction of rotation	bidirectional
Frame material	aluminum
Colour	RAL 7030
Cooling method	IC411
Ambient temperature	-20 / +40 °C
Altitude above sealevel	1000 m
Output	1.5kW
Speed	1420 rpm
Ins. Class	F
Efficiency	85,3% IE3
Voltage	400V
Connection	Y
F.L. Current	3.30A
Power factor	0,77
Duty	S1
Frequency	50 Hz
IP	55
Weight	19 kg

## ELECTRICAL TEST DATA

Ambient temperature	23 °C
Resistance of winding	6,091 Ω
Three phase current unbalanced	0,7 %
No load amps	2,27 A
No load input	122,2 W
Core loss (Pfe)	50,42 W
Windage friction loss (Pfw)	13,4 W
Stator winding loss (Pcu1)	136,7 W
Rotor winding loss (Pcu2)	65,6 W
Stray load loss (Ps)	7 W
Locked rotor current	25,41 A
Locked rotor current / Full load current	7,7
Full load torque	10,09 Nm
Locked rotor input power at full load	12905,1 W
Locked rotor torque	34,93 Nm
Locked rotor torque / Full load torque	3,46
Full load input	1772,4 W
Full load current	3,42 A
Efficiency at 50% load	81,01 %
Efficiency at 75% load	84,76 %
Efficiency at 100% load	84,63 %
Power factor at full load	0,748
Full load slip	4,131 %
Full load speed	1438
Stator winding temperature rise	44,24 K
Stator phase resistance at Ambient temperature of 95 °C	7,79 Ω
Sound pressure level	58 dB(A)
Vibration	1 mm/s
Insulation resistance	200 MΩ
Bearing temperature	57 °C

## SPECIAL DESIGN

Efficiency in compliance with IEC 60034-30 Edition 1.0 - 2008, IE3  
Testing method IEC 60034-2-1 Edition 1.0 - 2007-09

## DIMENSIONS 3F3A-90LA-4B14

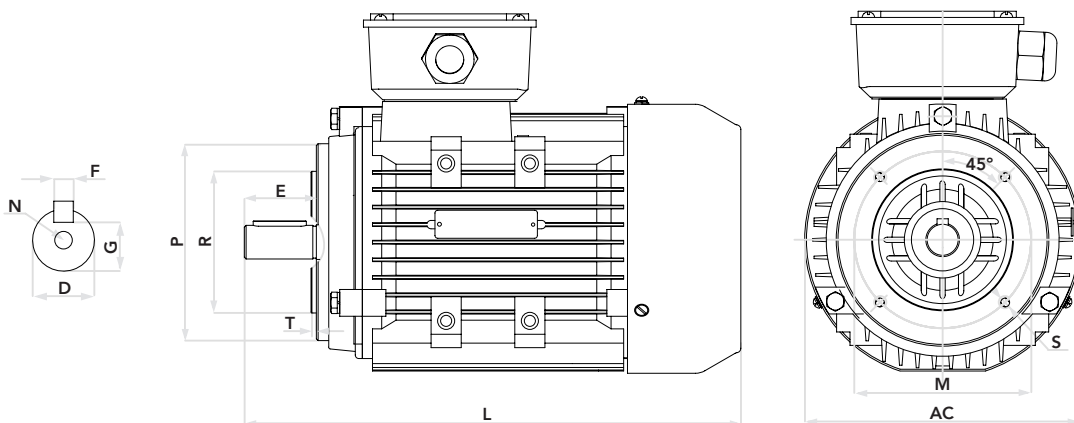

Frame size	Number of poles	D	E	F	G	M	R	P	S	T	AC	L	N
90LA	04	24	50	8	20	115	95	140	M8	3.0	195	380	M8

FELSTROM

3F3A-90LA-4B14

