

3F3A-80MB-2B5

MECHANICAL DATA

Noise at 50Hz	62 dB(A)
Moment of inertia	0.00169 kgm ²
Bearing DE	6204ZZ
Bearing NDE	6204ZZ
Bearing lifetime	40000 h
Direction of rotation	bidirectional
Frame material	aluminum
Colour	RAL 7030
Cooling method	IC411
Ambient temperature	-20 / +40 °C
Altitude above sealevel	1000 m
Output	1.1KW
Speed	2885 rpm
Ins. Class	F
Efficiency	82,7% IE3
Voltage	400V
Connection	Y
F.L. Current	2.31A
Power factor	0,83
Duty	S1
Frequency	50 Hz
IP	55
Weight	12,5 kg

SPECIAL DESIGN

ELECTRICAL TEST DATA

Ambient temperature	17 °C
Resistance of winding	11,129 Ω
Three phase current unbalanced	7,52 %
No load amps	1,346 A
No load input	165,5 W
Core loss (Pfe)	39,36 W
Windage friction loss (Pfw)	31,08 W
Stator winding loss (Pcu1)	118,8 W
Rotor winding loss (Pcu2)	38,24 W
Stray load loss (Ps)	32,55 W
Locked rotor current	19,91 A
Locked rotor current / Full load current	8,62
Full load torque	3,67 Nm
Locked rotor input power at full load	10915 W
Locked rotor torque	13,19 Nm
Locked rotor torque / Full load torque	3,59
Full load input	1360 W
Full load current	2,331 A
Efficiency at 50% load	78,77 %
Efficiency at 75% load	81,69 %
Efficiency at 100% load	80,86 %
Power factor at full load	0,8423
Full load slip	3,182 %
Full load speed	2904 rpm
Stator winding temperature rise	58,38 K
Stator phase resistance at Ambient temperature of 95 °C	14,573 Ω
Sound pressure level	61 dB(A)
Vibration	1 mm/s
Insulation resistance	200 MΩ
Bearing temperature	42 °C

Efficiency in compliance with IEC 60034-30 Edition 1.0 - 2008, IE3
Testing method IEC 60034-2-1 Edition 1.0 - 2007-09

DIMENSIONS 3F3A-80MB-2B5

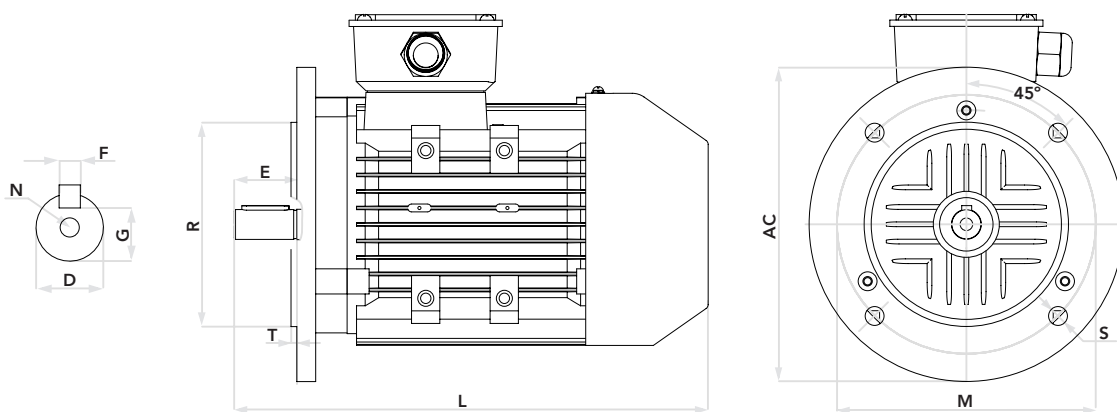

Frame size	Number of poles	D	E	F	G	M	N	R	S	T	AC	L
80MB	02	19	40	6	15.5	165	M6	130	4-12	3.5	175	300

FELSTROM

3F3A-80MB-2B5

