

3F3A-132SB-2B14

MECHANICAL DATA

Noise at 50Hz	79 dB(A)
Moment of inertia	0.02285 kgm ²
Bearing DE	6208ZZ
Bearing NDE	6208ZZ
Bearing lifetime	40000 h
Direction of rotation	bidirectional
Frame material	aluminum
Colour	RAL 7030
Cooling method	IC411
Ambient temperature	-20 / +40 °C
Altitude above sealevel	1000 m
Output	7.5kW
Speed	2925 rpm
Ins. Class	F
Efficiency	90,1% IE3
Voltage	400V
Connection	D
F.L. Current	13.7A
Power factor	0,88
Duty	S1
Frequency	50 Hz
IP	55
Weight	62 kg

ELECTRICAL TEST DATA

Ambient temperature	25,6 °C
Resistance of winding	0,852 Ω
Three phase current unbalanced	2,33 %
No load amps	4,44 A
No load input	416,4 W
Core loss (Pfe)	158,18 W
Windage friction loss (Pfw)	116 W
Stator winding loss (Pcu1)	290,9 W
Rotor winding loss (Pcu2)	181,1 W
Stray load loss (Ps)	120,8 W
Locked rotor current	115,08 A
Locked rotor current / Full load current	8,4
Full load torque	24,5 Nm
Locked rotor input power at full load	38966 W
Locked rotor torque	58,31 Nm
Locked rotor torque / Full load torque	2,38
Full load input	8366 W
Full load current	13,41 A
Efficiency at 50% load	89,05 %
Efficiency at 75% load	89,75 %
Efficiency at 100% load	89,65 %
Power factor at full load	0,9006
Full load slip	2,521 %
Full load speed	2924,37 rpm
Stator winding temperature rise	67,99 K
Stator phase resistance at Ambient temperature of 95 °C	1,618 Ω
Sound pressure level	72 dB(A)
Vibration	0,9 mm/s
Insulation resistance	200 MΩ
Bearing temperature	52,8 °C

SPECIAL DESIGN

Efficiency in compliance with IEC 60034-30 Edition 1.0 - 2008, IE3
Testing method IEC 60034-2-1 Edition 1.0 - 2007-09

DIMENSIONS 3F3A-132SB-2B14

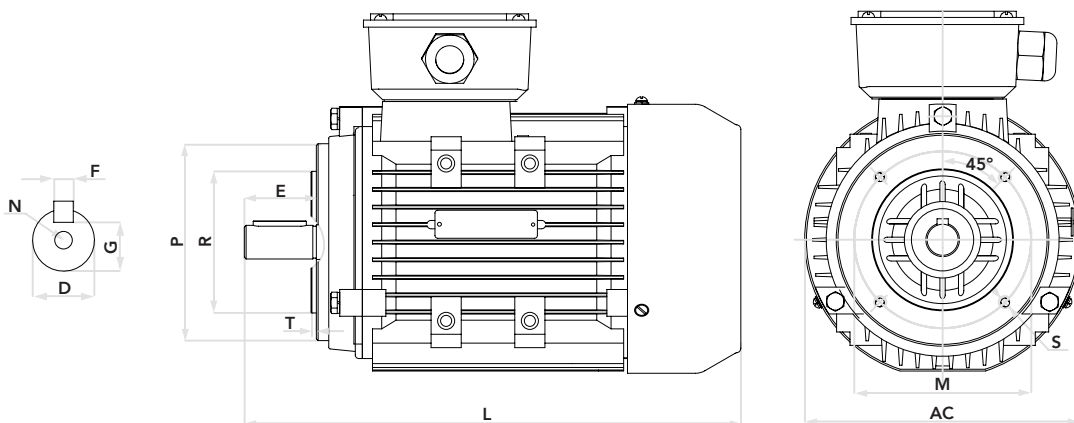

Frame size	Number of poles	D	E	F	G	M	R	P	S	T	AC	L	N
132SB	02	38	80	10	33	165	130	218	M10	4	275	470	M12

FELSTROM

3F3A-132SB-2B14

